

# DECK ATTACHMENT SHEET

**This document is to remain with your plans at all times**

PROJECT ADDRESS:

YES NO

DECK DESIGN INCLUDES A SOLID COVER OR PERGOLA STYLE COVER

ELECTRICAL SERVICE AND METER LOCATION MAY BE AFFECTED BY DECK, RECOMMEND DISCUSSION WITH ELECTRICAL DEPARTMENT IF YES.

DECK SUPPORTS HOT TUB OR SPA LOADING

DECK IS SUPPORTED BY CANTILEVER AT HOUSE EXISTING INVERTED HANGER INSTALLATION WAS VERIFIED OR ENGINEERING WAS PROVIDED

LESS THAN 18" ABOVE GRADE

**USE LISTED JOIST HANGERS TO MATCH JOIST SIZE AND PROVIDE LISTED HARDWARE AT POST CAP AND BASE. INSTALL ALL LISTED PRODUCTS PER THE MANUFACTURER'S RECOMMENDATIONS (USP/SIMPSON/ETC..)**

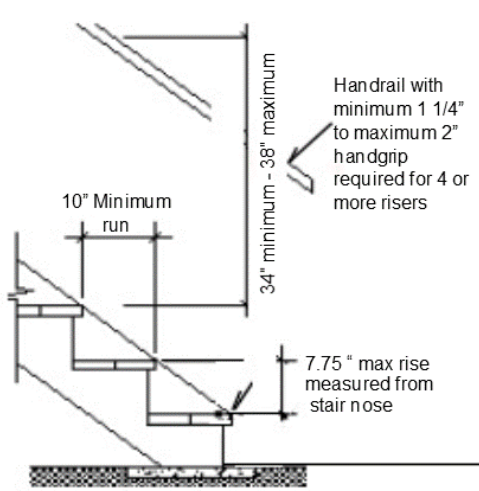

24" maximum horizontal span between PT Hem Fir stringers. Maximum 3/8" tread & rise difference

**STAIR DETAILS**

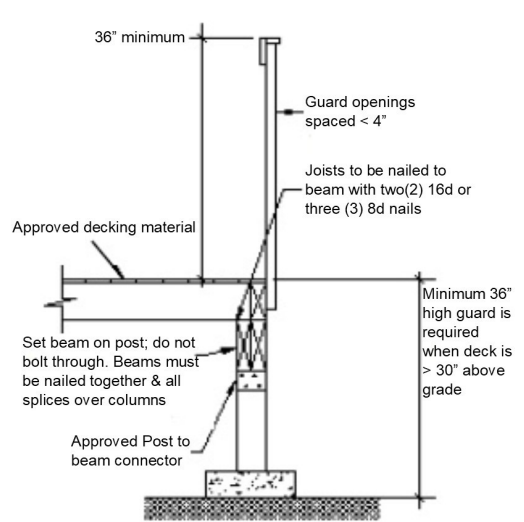

Set beam on post; do not bolt through. Beams must be nailed together & all splices over columns

**GUARD DETAILS**

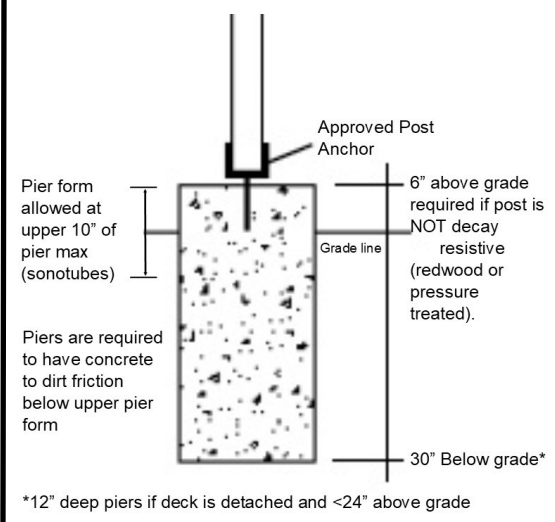

Piers are required to have concrete to dirt friction below upper pier form

\*12" deep piers if deck is detached and <24" above grade

**FOOTING DETAILS**

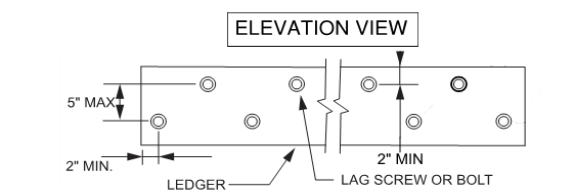
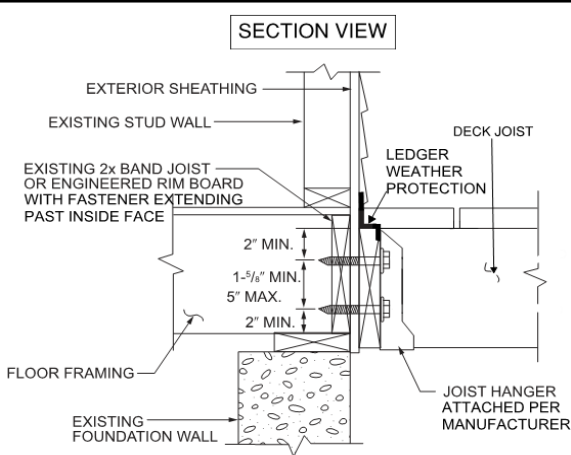

**LEDGER DETAILS**

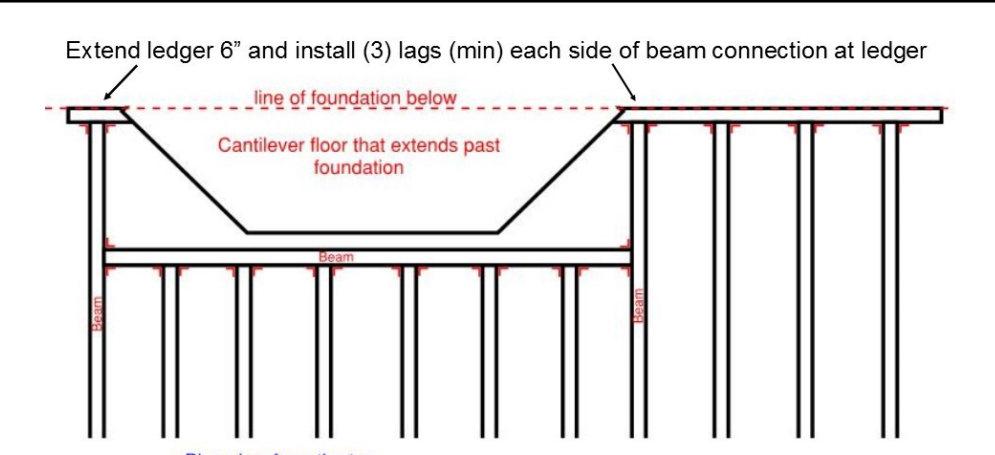

Plan view from the top

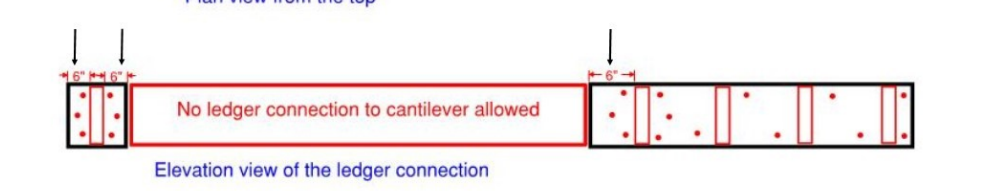

**CANTILEVER DETAILS**